

# APPLICATION EXAMPLE

## VIRTUAL REALITY



# OVERVIEW

## VIRTUAL REALITY APPLICATION

### CUSTOMER FACTS OVERVIEW

Branch:  
Virtual Reality

Information:

**Nomada Omnimotion** is a Spain based developer of a new solution that enhances the Virtual Reality experience. With the omnidirectional treadmill the user can now walk in any direction while using the VR-Goggles, which not only lifts the experience to a higher level of realism but also prevents motion sickness.

### NEXT LEVEL APPLICATIONS MOVEMENT IN VIRTUAL REALITY

Being an extremely fast growing industry the Virtual Reality Market spawns some very innovative and exciting solutions that create the most immersive ways of experiencing virtual surroundings. Whether it is used for the **gaming sector or for business purposes**, being able to walk in every direction while wearing VR-Goggles, has an extreme impact on the whole experience.

To realize this omnimotional platform, Nomada Omnimotion was looking for a **conveyor system** that was able to cover all the demands that were necessary for this innovative project:

- [satisfying delivery time](#)
- [competitive price](#)
- [well elaborated and detailed technical study](#)
- [integral solution with the union structure between the two parts](#)



In this case Nadella was pleased to offer the **AXNRO Circular Systems (R-Modules)** connected by **cardan shaft**. This was a proper solution for this project and with a delivery time **two weeks shorter than of the competitor's** and with a very cost-effective offer, Nadella was able to cater the right solution. The conducted **detailed technical study and the good integrity** with the union structure were another important point that Nadella was able to fulfill.

The customer was very satisfied with the **quality, repeatability precision and the service** offered by Nadella.

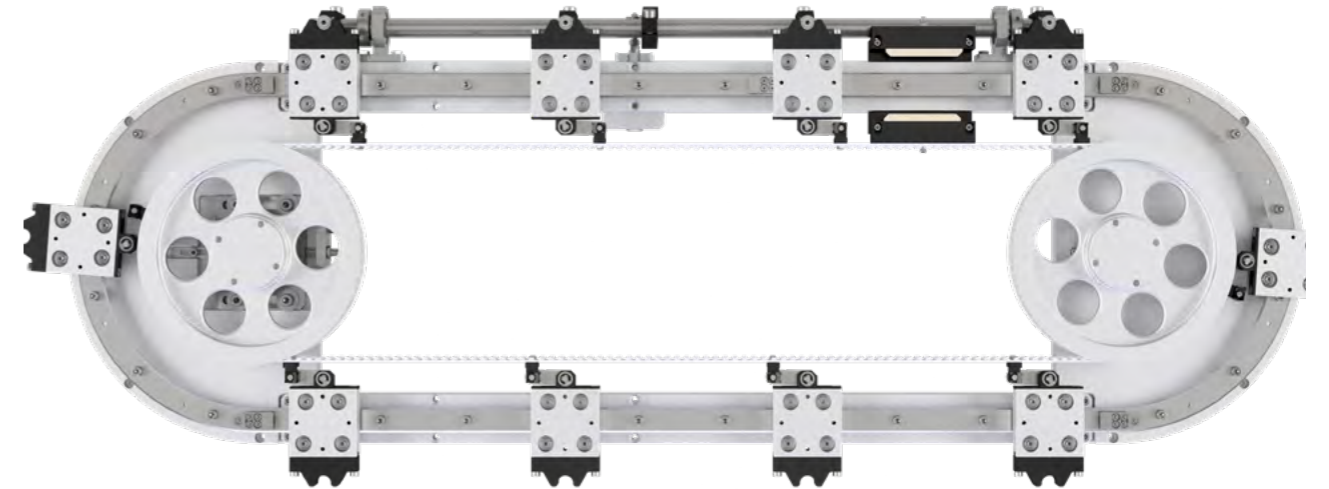

### NADELLA **AXNRO SYSTEM**

#### COMPONENTS FOR INNOVATIVE MOVEMENT

With its properties of **efficiency, reliability and customization** the AXNRO was the right fit for this project.

The platform consists of the lateral concatenation of **several conveyor belts surrounding a chassis**. On one hand, the conveyor belts are responsible for movement in one direction (x), while the second direction (y) is achieved by **moving all these belts around the chassis**.

This is realized by **two parallel AXNRO Systems** that circulate 12 conveyor belts.

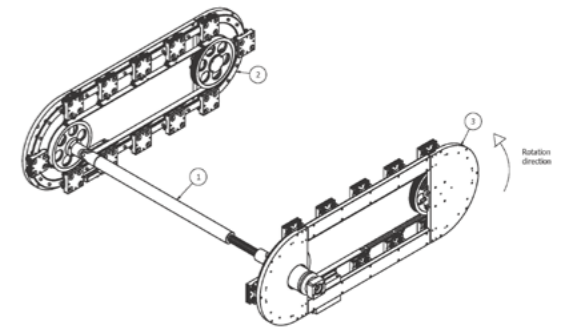

#### PRODUCTS USED IN THIS PROJECT

Type

[Cardan Shaft WE2-133](#)

[AXNRO35M-225-1017-12](#)

[DOWNLOAD OUR AXNR CATALOGUE](#)

[ANY QUESTIONS? CONTACT US](#)

[SEE MORE APPLICATIONS](#)



**NADELLA** / [nadella.com](http://nadella.com)

**DURBAL** / [durbal.com](http://durbal.com)

**CHIAVETTE UNIFICATE** / [chiavette.com](http://chiavette.com)

**IPIRANGA** / [ipirangahusillos.com](http://ipirangahusillos.com)

**SHUTON** / [shuton.com](http://shuton.com)

**THE SPECIALIST FOR MOTION TECHNOLOGY**